

**STÛV 6** (86 X 60 MODEL)

---

**SPECIFICATIONS &  
MANUFACTURER  
INSTALLATION  
GUIDE**

**stûv**

LE FEU ESSENTIEL

Congratulations on your purchase of the STUV 6. This appliance should be installed and checked by a qualified professional. Ensure you have read the operation guidelines thoroughly prior to first use.

**CAUTION:**

Using components or parts other than those provided by the manufacturer or modifying the specification of components may result in inferior or unsafe operation.

**WARNING:**

- The appliance and flue-system must be installed in accordance with AS/NZS 2918 and the relevant building code or codes.
- Any modification of the appliance that has not been approved in writing by the testing authority will be in breach of the approval granted for compliance with AS/NZS 4013.
- Once the flue has been installed and approved by a professional installer, the flue must not be modified in any way.

# DIMENSIONS & TECHNICAL DATA

## STUV 6 - DIMENSIONS OF THE DEVICE WITHOUT THE DECORATIVE FRAME AND WITHOUT OPTIONAL EXTRAS

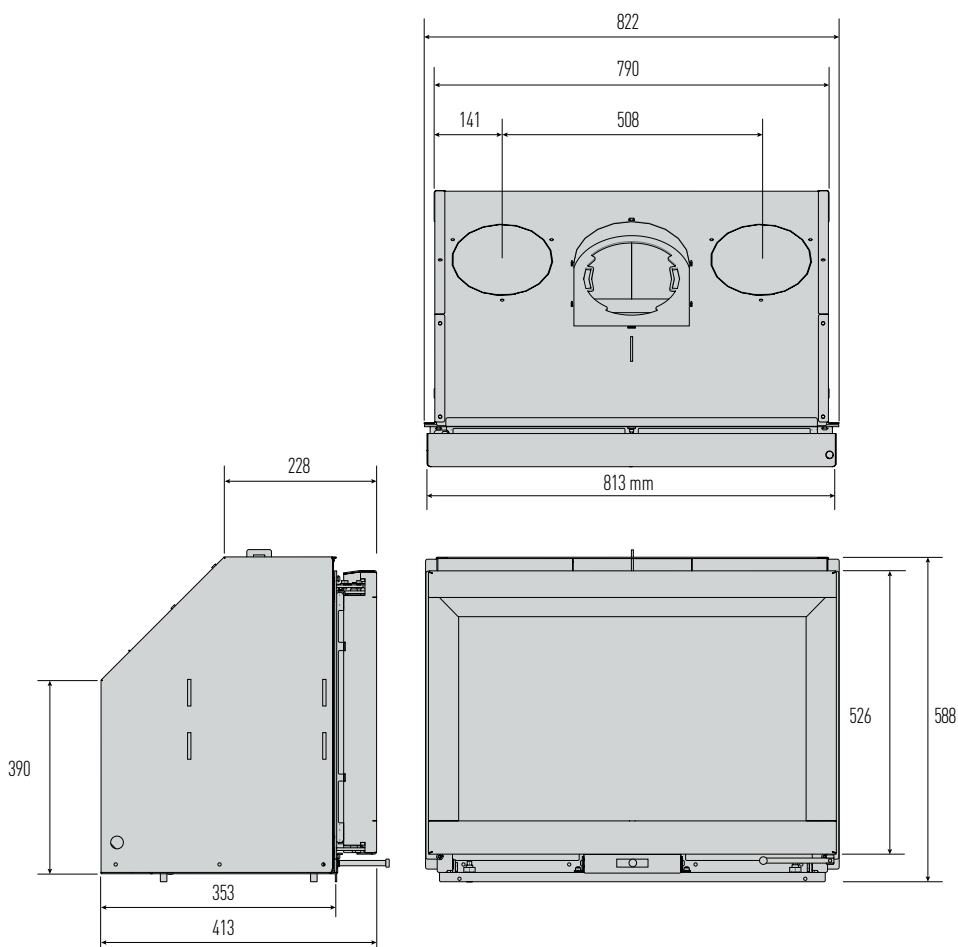

### WEIGHT AND DIMENSIONS:

Firebox external dimensions	W822 x H588 x D413mm
Firebox weight	115Kg
Flue system	Solid 6" or Flexi 6"

### DETERMINED UNDER TEST CONDITIONS:

Nominal thermal output	7kW
Efficiency (Australian Test)	68%
Emissions (Australian Test)	1.1 g/Kg

# OVERVIEW

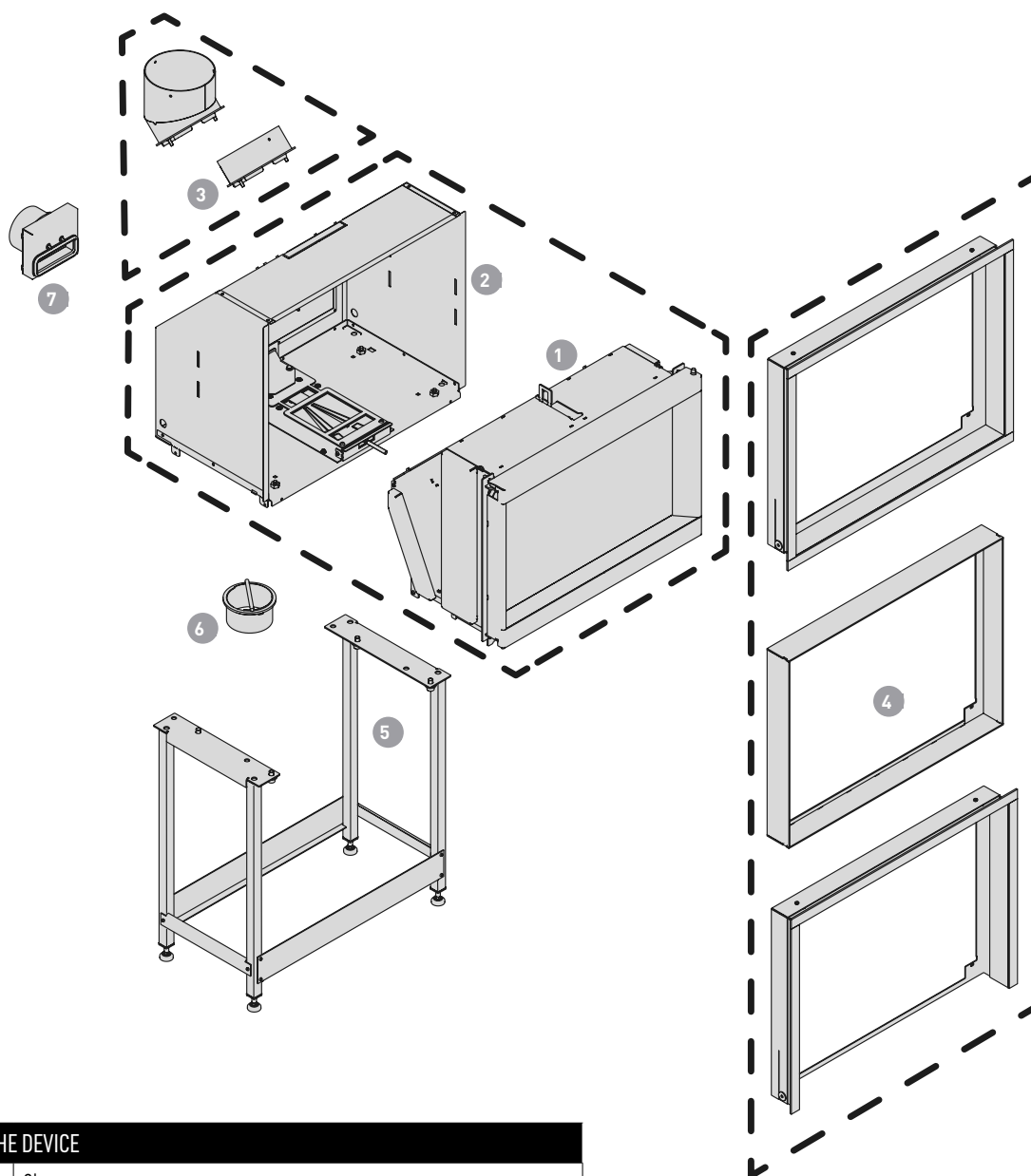

THE DEVICE	
1	Stove
2	Support casing
CONNECTION TO THE COMBUSTION SMOKE OUTLET PIPE	
3	Smoke outlet connection piece (vertical or 45° angle)
FINISH	
4	Decorative frames
OPTIONS	
5	Stand
6	Nozzle Ø100mm for external air inlet from the bottom
7	Rear external air connection kit Ø100mm

# DECORATIVE FRAMING OPTIONS

## THIN FLUSH FRAME (mm)

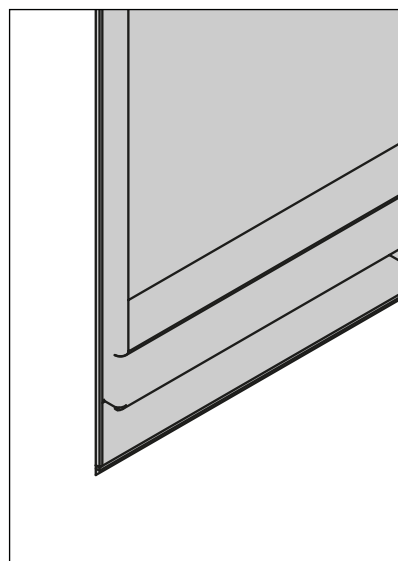
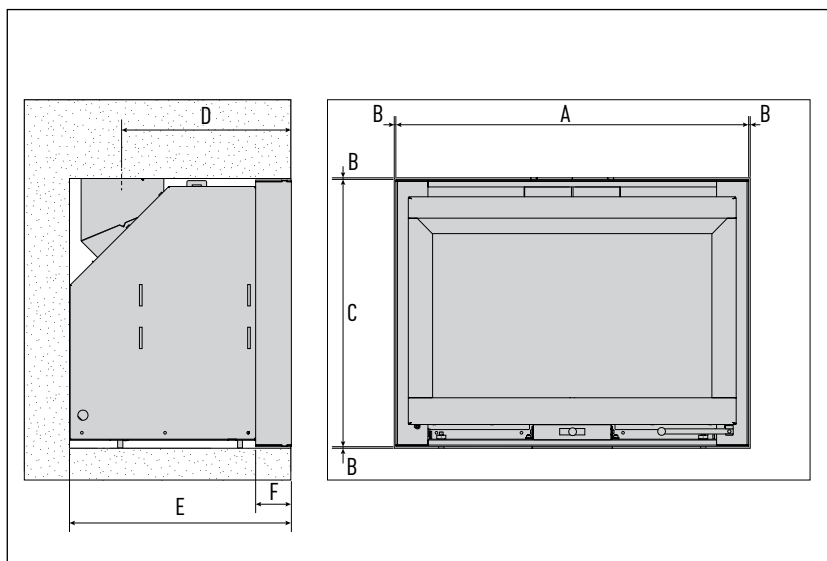

	A	*B	C	D	E	F
Stuv 6 – 86 x 60	860	4	600	317	415	67

\*Expansion joint that must be respected around the decorative frame

## THIN EXTENDED FRAME (mm)

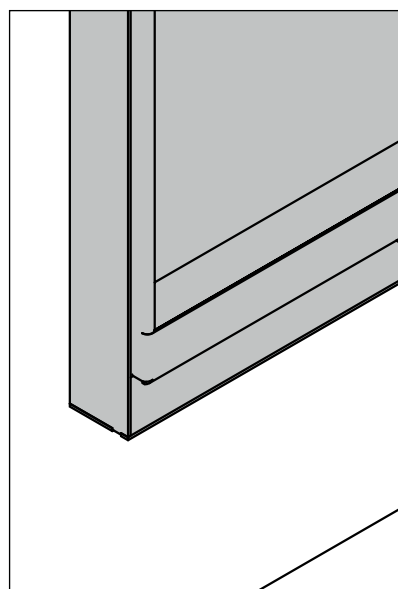
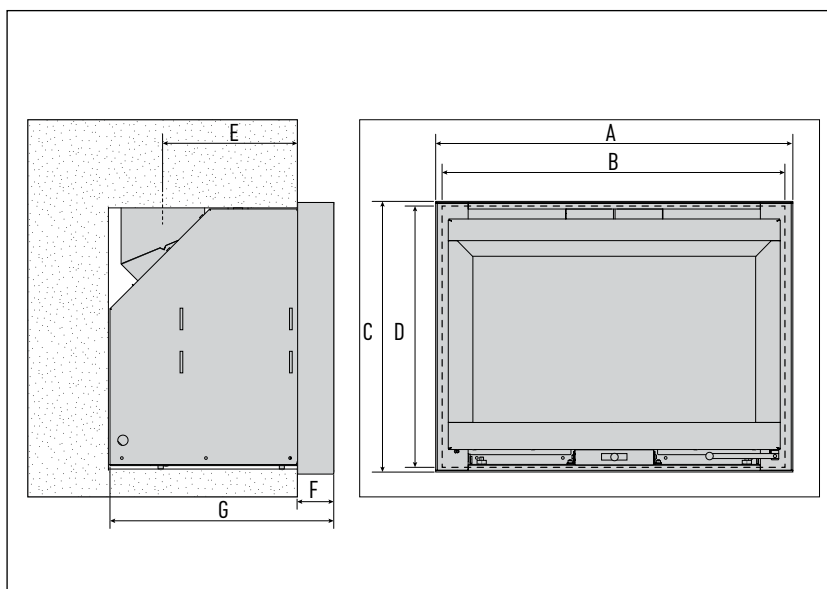

	A	B	C	D	E	F	G
Stuv 6 – 86 x 60	860	822	600	578	250	67	415

# DECORATIVE FRAMING OPTIONS

## FITTED FRAME 4 SIDES (mm)

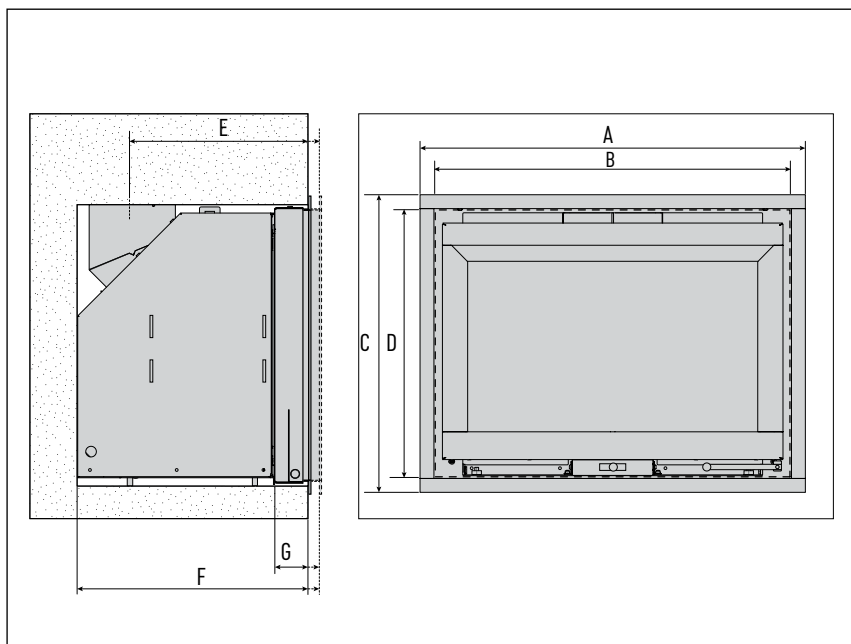

	A	B	C	D	E	F	G
Stuv 6 – 86 x 60	894	860	636	600	316 (-0/+20)	413 (-0/+20)	60 (-0/+20)

## FITTED FRAME 3 SIDES (mm)

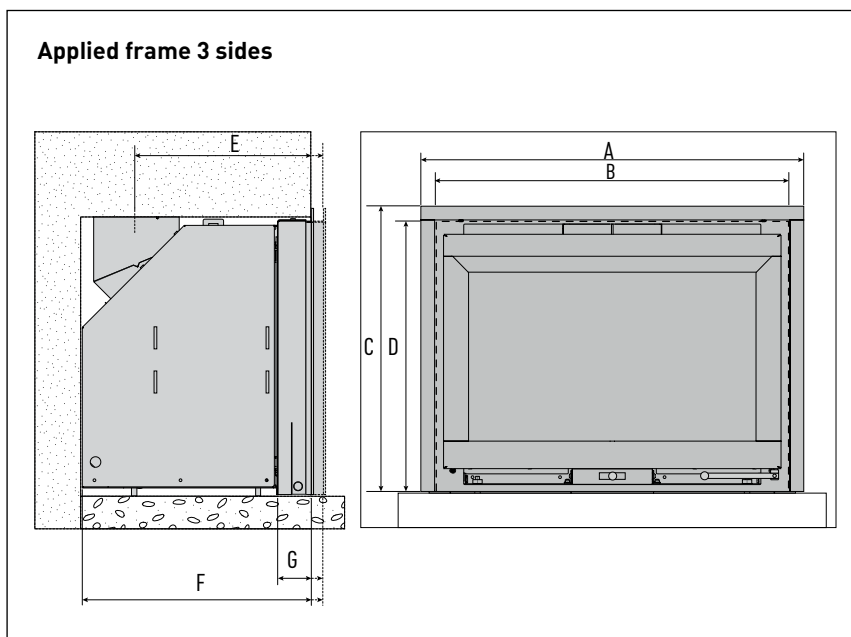

	A	B	C	D	E	F	G
Stuv 6 – 86 x 60	896	860	619	595	316 (-0/+20)	413 (-0/+20)	60 (-0/+20)

# 6" FLUE AND 100MM AIR INTAKE CONNECTIONS

## Dimensions of the smoke outlet at 45°

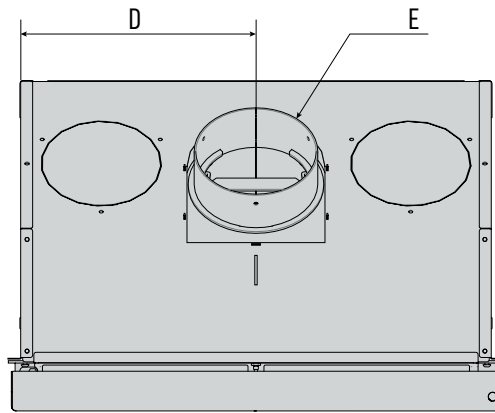
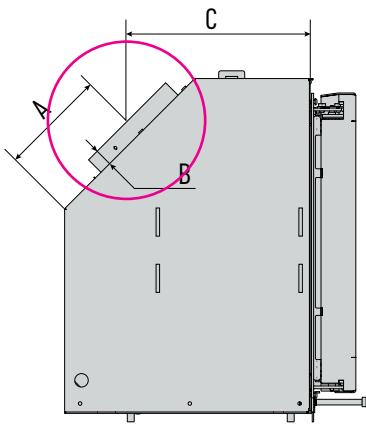

	mm
A	149
B	29
C	262
D	395
E	180

## Dimensions of the smoke outlet upwards

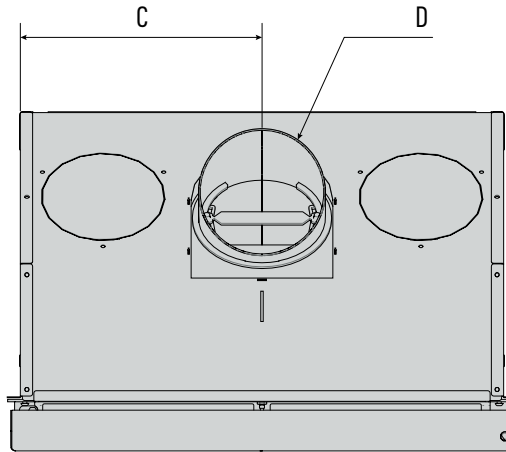
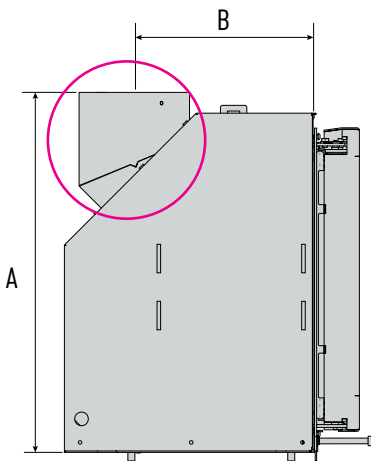

	mm
A	605
B	251
C	395
D	180

# 6" FLUE AND 100MM AIR INTAKE CONNECTIONS

## Dimensions of the connection to the external air inlet at the rear

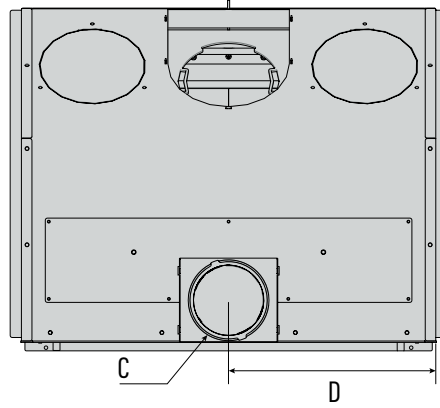
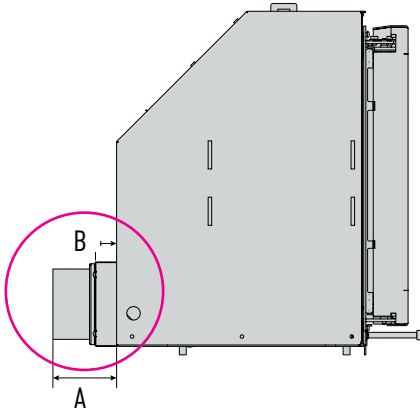

	mm
A	70
B	31
C	100
D	395

## Dimensions of the connection to the external air inlet at the bottom

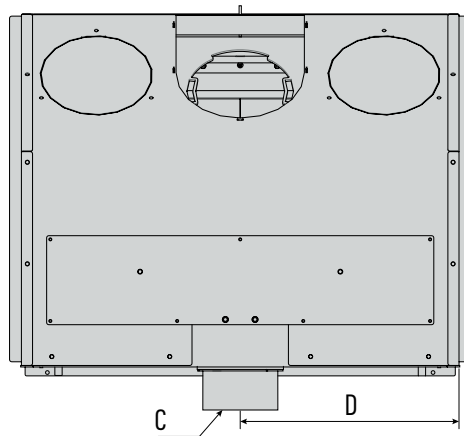
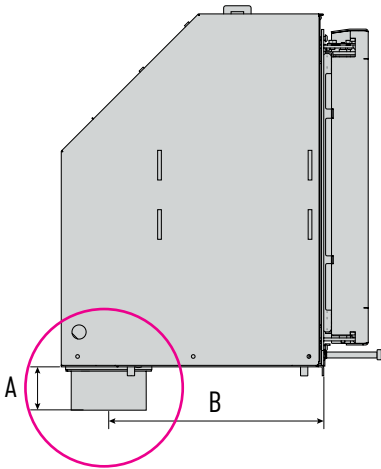

	mm
A	59
B	290
C	100
D	395



# ADJUSTABLE FIREBOX STAND

## Dimensions of the stand

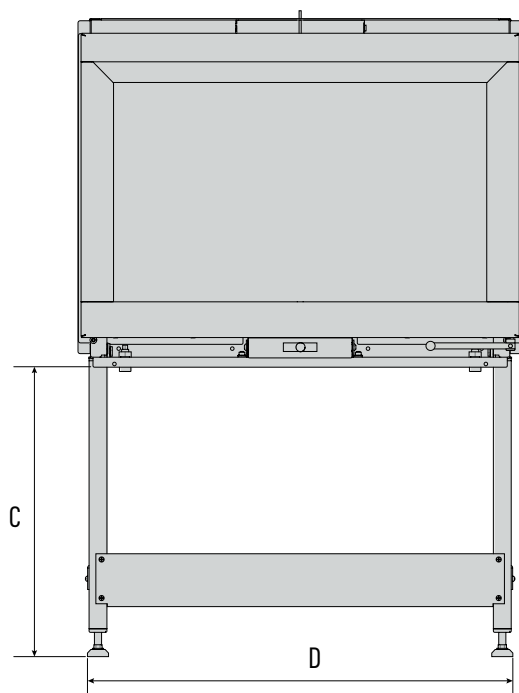
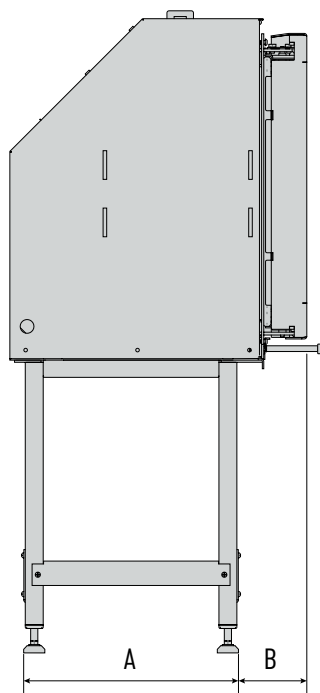

	mm
A	300
B	95
C	50 to 600
D	796

## 2.2 FRAMING CLEARANCES

### MASONRY INSTALLATION

**Stuv 6 is a zero clearance box to masonry. Allowing a small expansion gap is recommended to prevent possible damages to the firebox or surrounding materials.**

**IMPORTANT: The fireplace is not load bearing**

### CLEARANCES TO COMBUSTIBLE MATERIAL

With Silicate Board

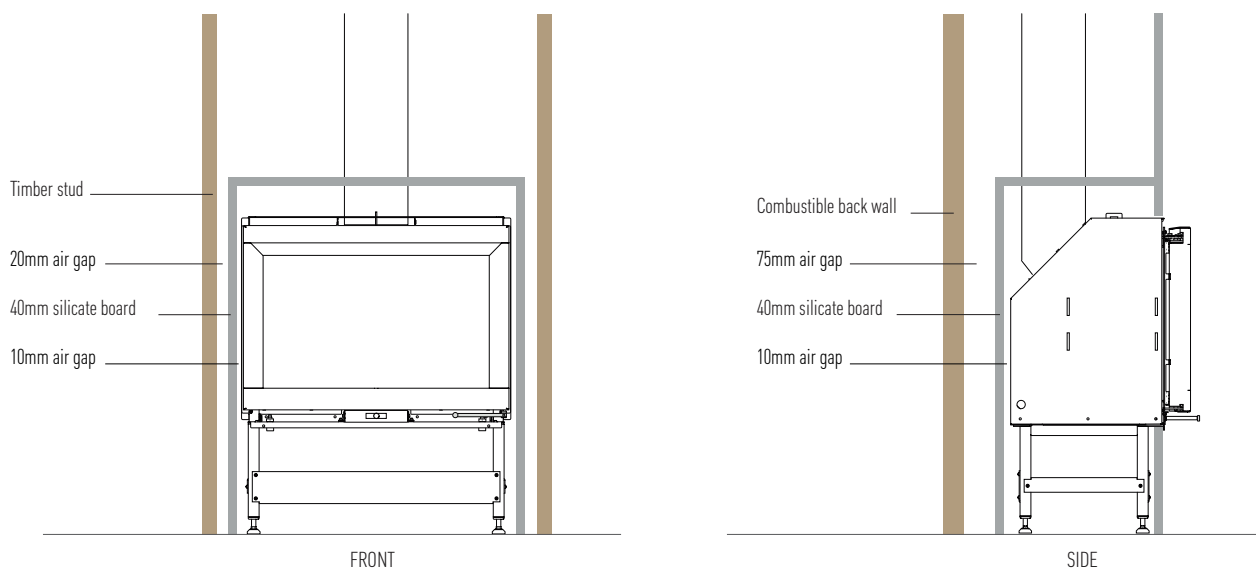

Without insulative board

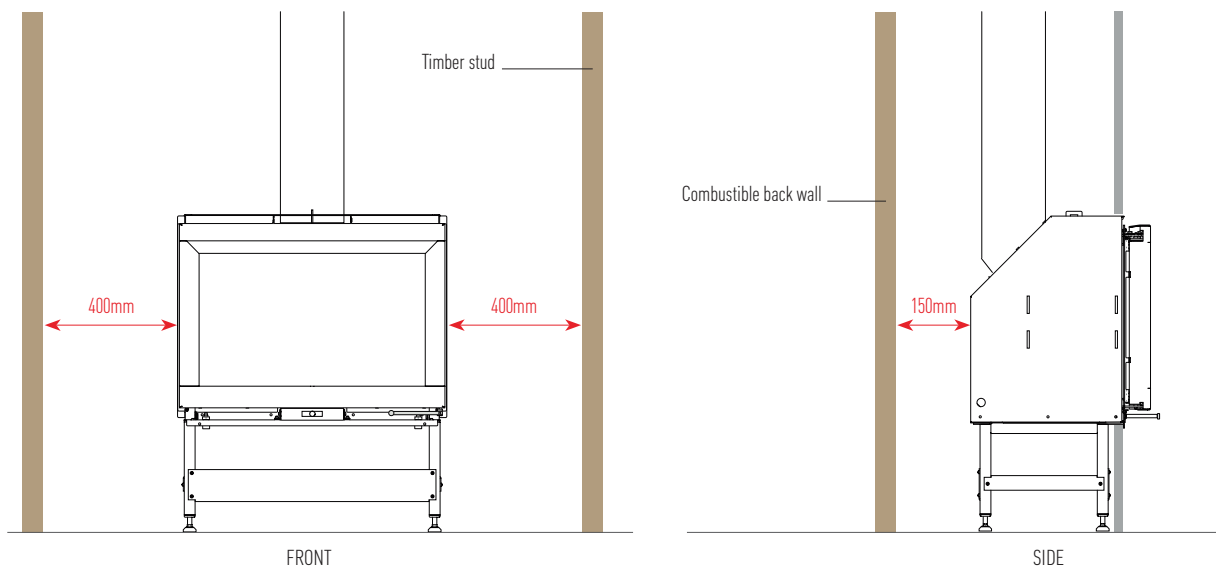

# FLOOR PROTECTOR

**Any combustible floor beneath a fireplace must have a floor protector that also extend in front of the appliance.**

**If the fireplace is installed on a concrete, masonry or non combustible floor there is no requirement for a floor protector.**

## COMBUSTIBLE FLOOR INSTALLATION - FIREBOX IS INSTALLED BELOW 400MM HEIGHT

Floor protector must be minimum 42mm thick cement sheet (excluding non combustible floor finish)

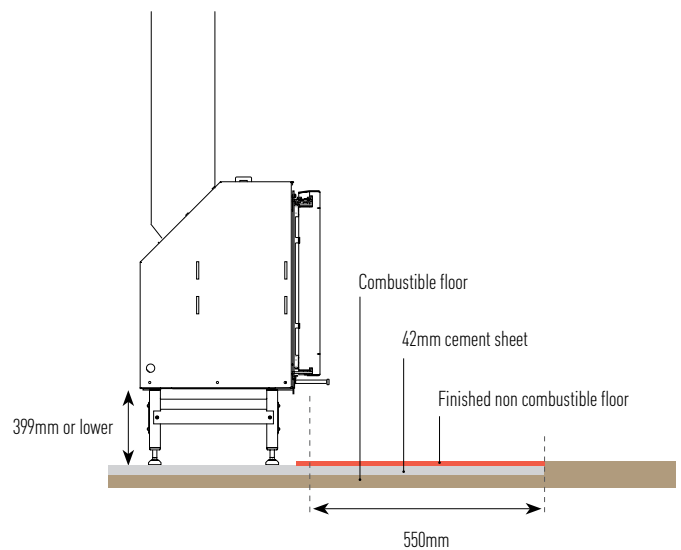
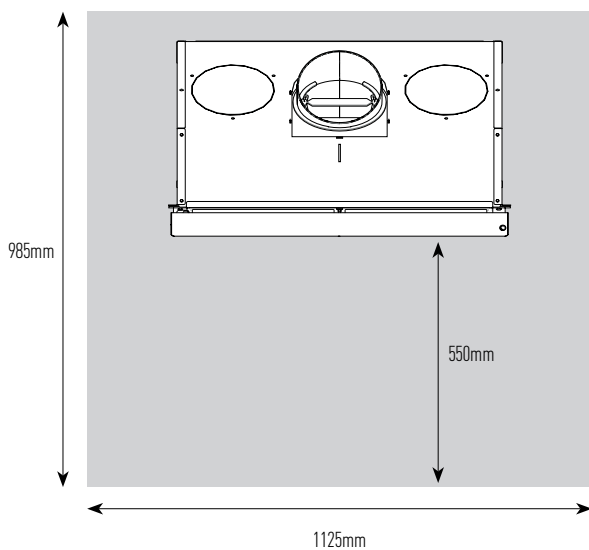

## COMBUSTIBLE FLOOR INSTALLATION - FIREBOX IS INSTALLED AT 400MM HEIGHT OR ABOVE

Floor protector must be minimum 9mm thick cement sheet (excluding non combustible floor finish)

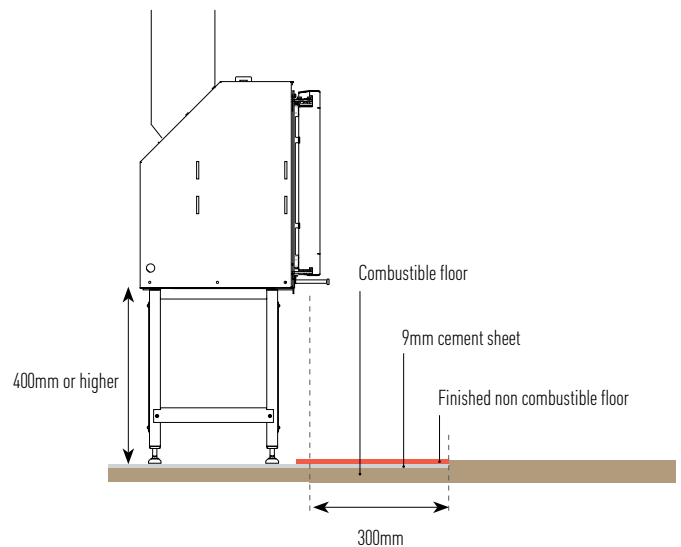
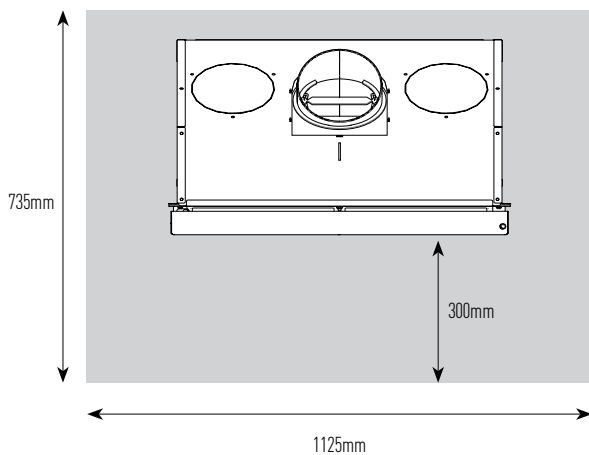

# SETTING UP THE CONNECTIONS

The STUV 6 is specifically designed so that it is easy to connect to outside air intake (optional) and smoke outlet (flue). The connections are carried out from the inside of the unit once fitted.

So before fitting the unit, prepare the connections as per below:

## OUTSIDE AIR INTAKE - REAR OR BACK (OPTIONAL)

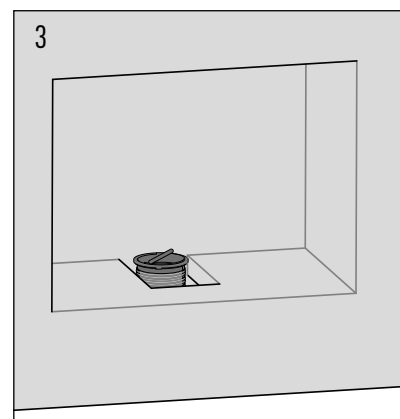
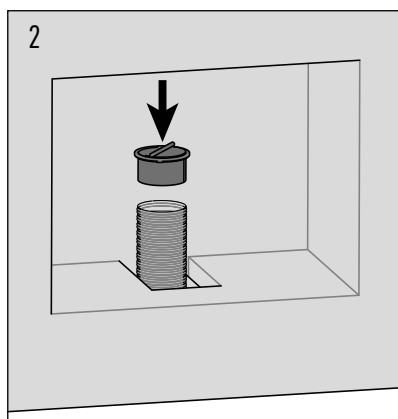
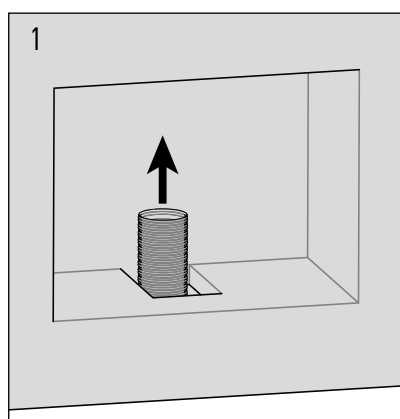

Install the air inlet duct and attach the nozzle with a metal duct clamp.

## FLUE

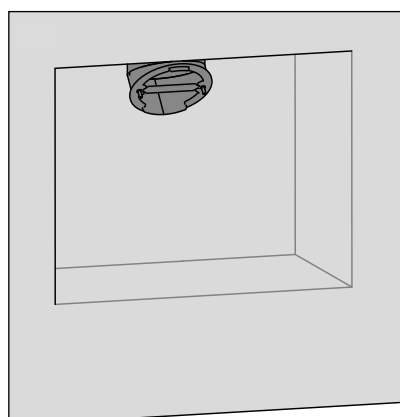

Install the flexible or solid flue so that it comes out close to where the appliance outlet will be located. Attach the smoke outlet connection provided with the fireplace (if using a flexi flue, use a metal duct clamp - not provided).

# GETTING THE UNIT READY FOR INSTALL

Dismantling the unit allows an easier handling process and give access to the different connections

## STEP 1: DISMANTLE THE DOOR

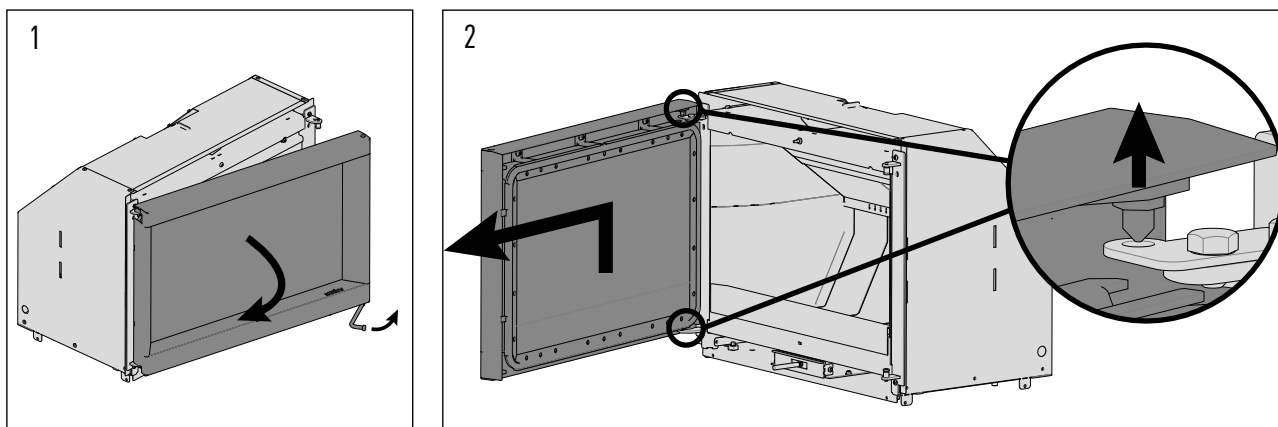

## STEP 2: REMOVE THE SMOKE DEFLECTORS

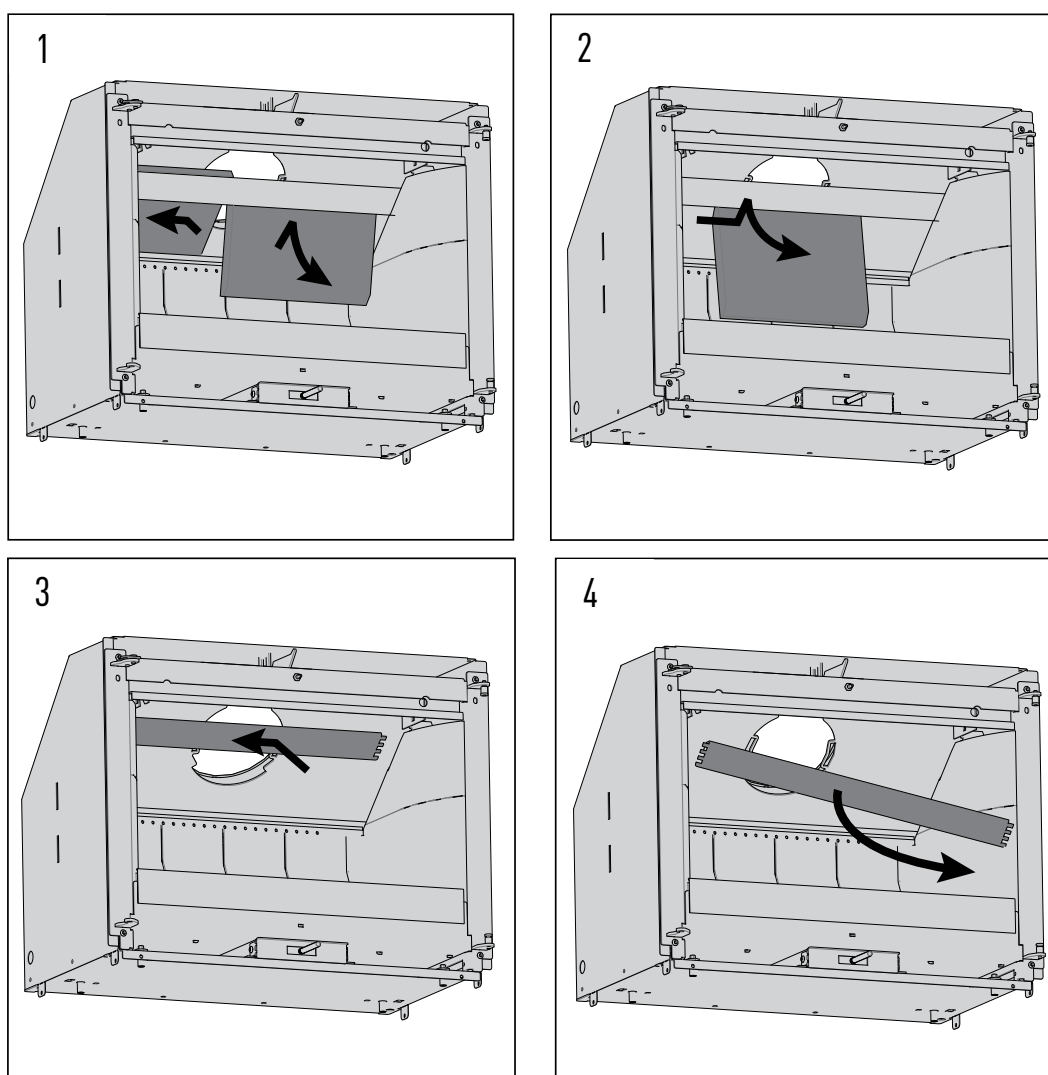

# GETTING THE UNIT READY FOR INSTALL

## STEP 3: SEPARATING SUPPORT CASING & COMBUSTION CHAMBER

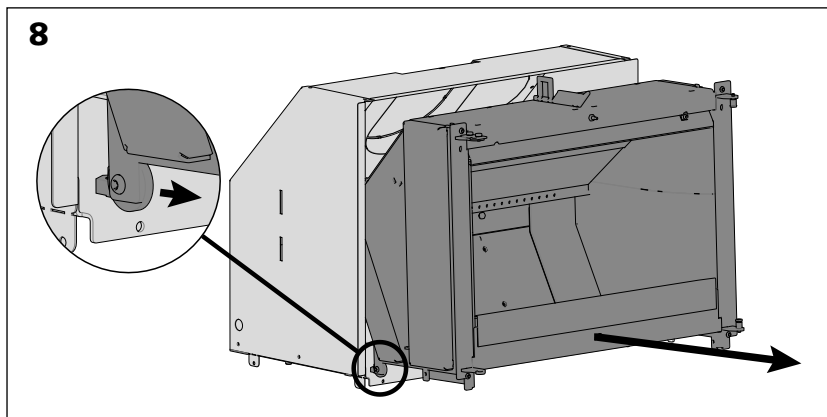
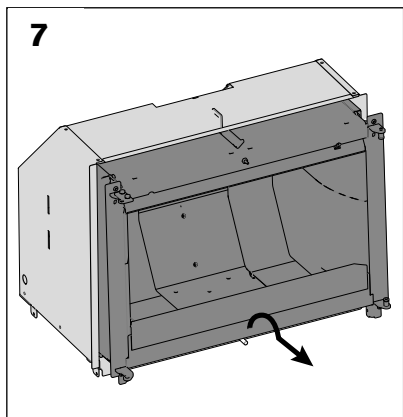
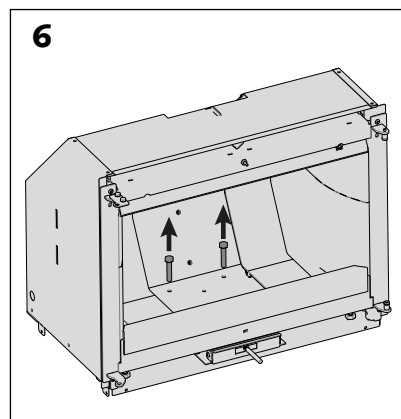
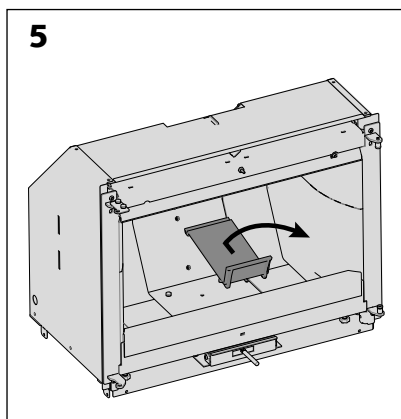
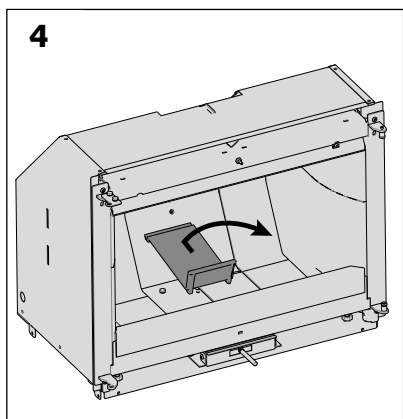
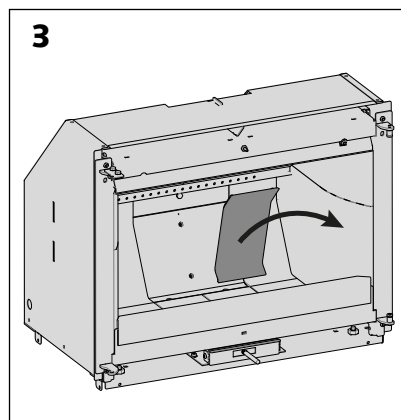
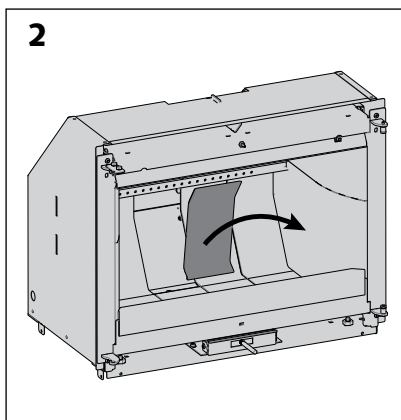
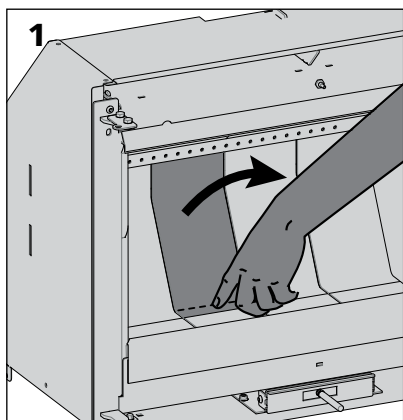

# THREE OPTIONS FOR COMBUSTION AIR SUPPLY

## OPTION #1: BOTTOM CONNECTION

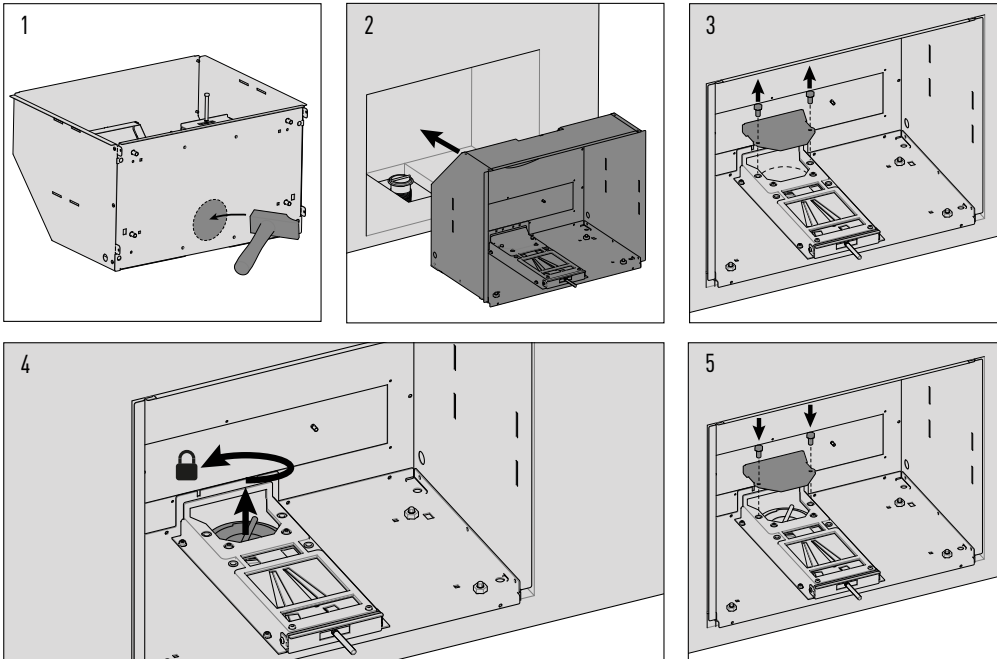

## OPTION #2: REAR CONNECTION

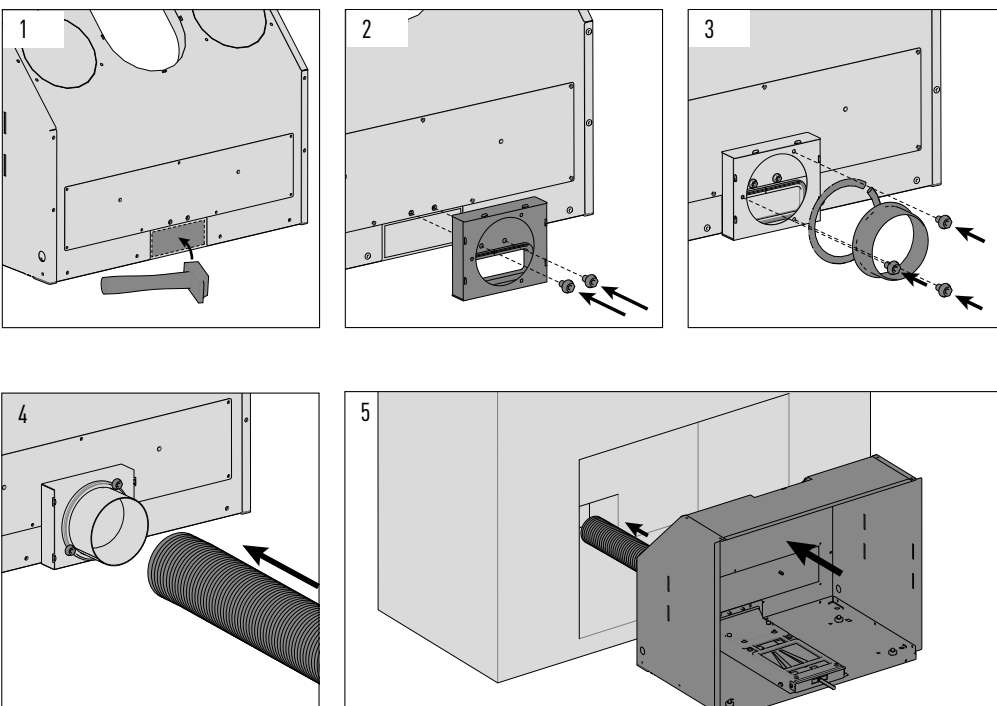

# THREE OPTIONS FOR COMBUSTION AIR SUPPLY

## OPTION #3: THROUGH THE FRAME

If you choose to get the air for combustion through the frame make sure you follow these simple steps:

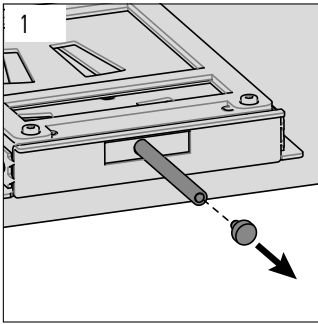

1. Remove the head from the Damper.

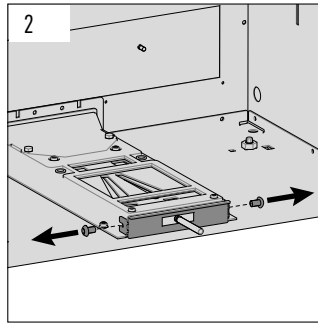

2. Remove the 2 side screws.

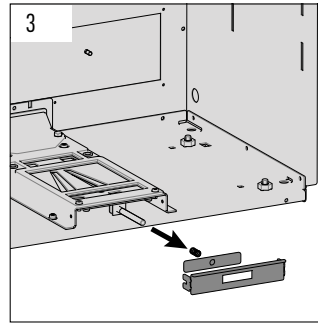

3. Remove the 2 plates and the spring.  
4. Put the Damper Head back on.



# POSITIONING THE OUTER CASING

## OPTION #1: OUTER CASING INSTALL IN A RECESS

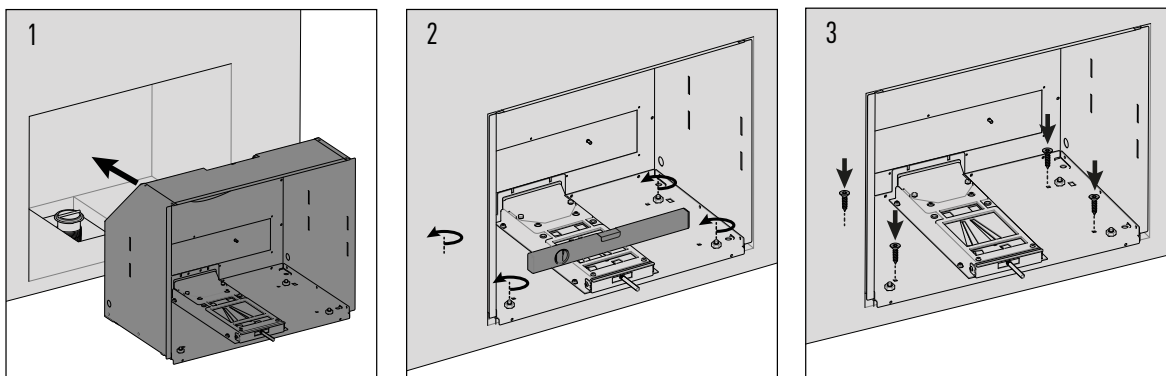

## OPTION #2: OUTER CASING INSTALLED ON ITS STAND

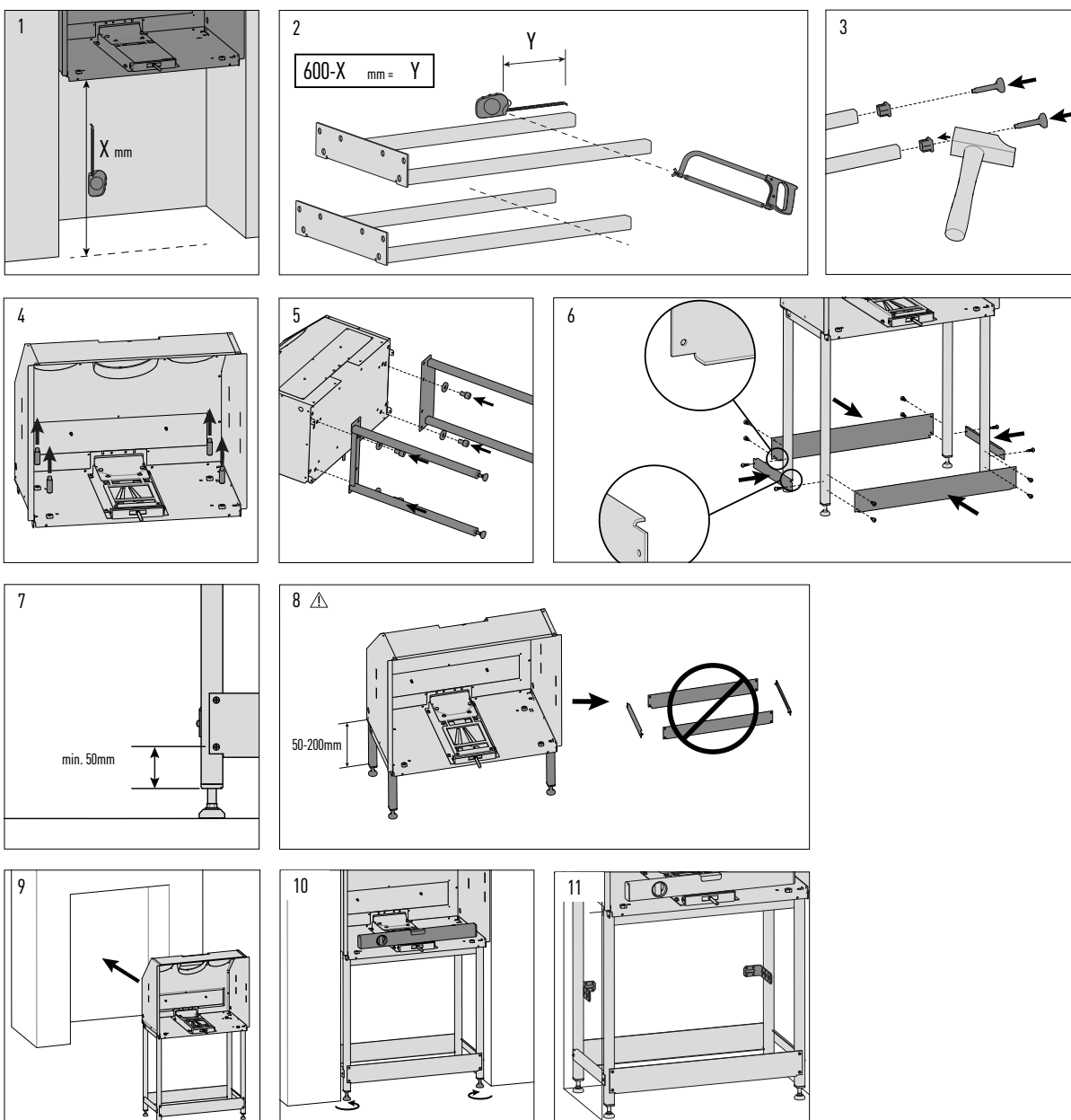

# REASSEMBLING THE COMBUSTION CHAMBER IN THE OUTER CASING

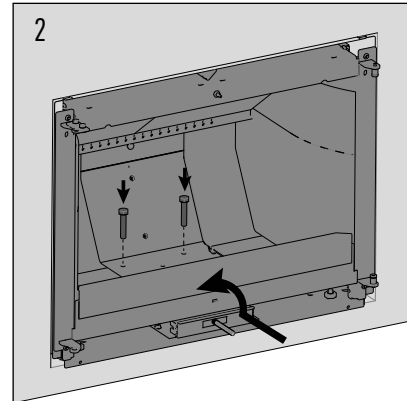
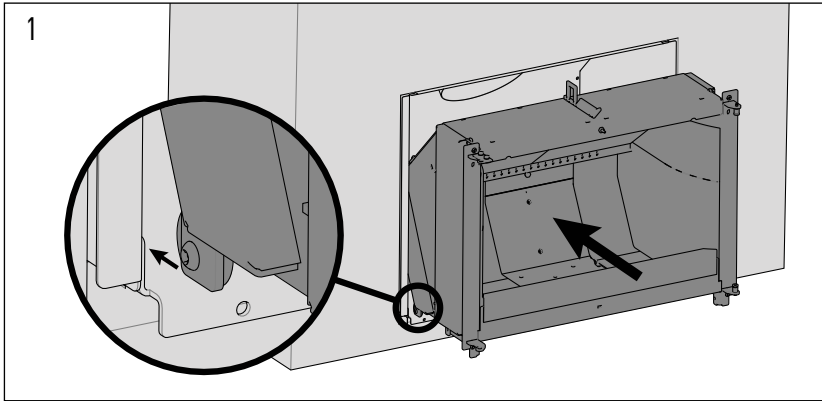

# CONNECTING THE FLUE

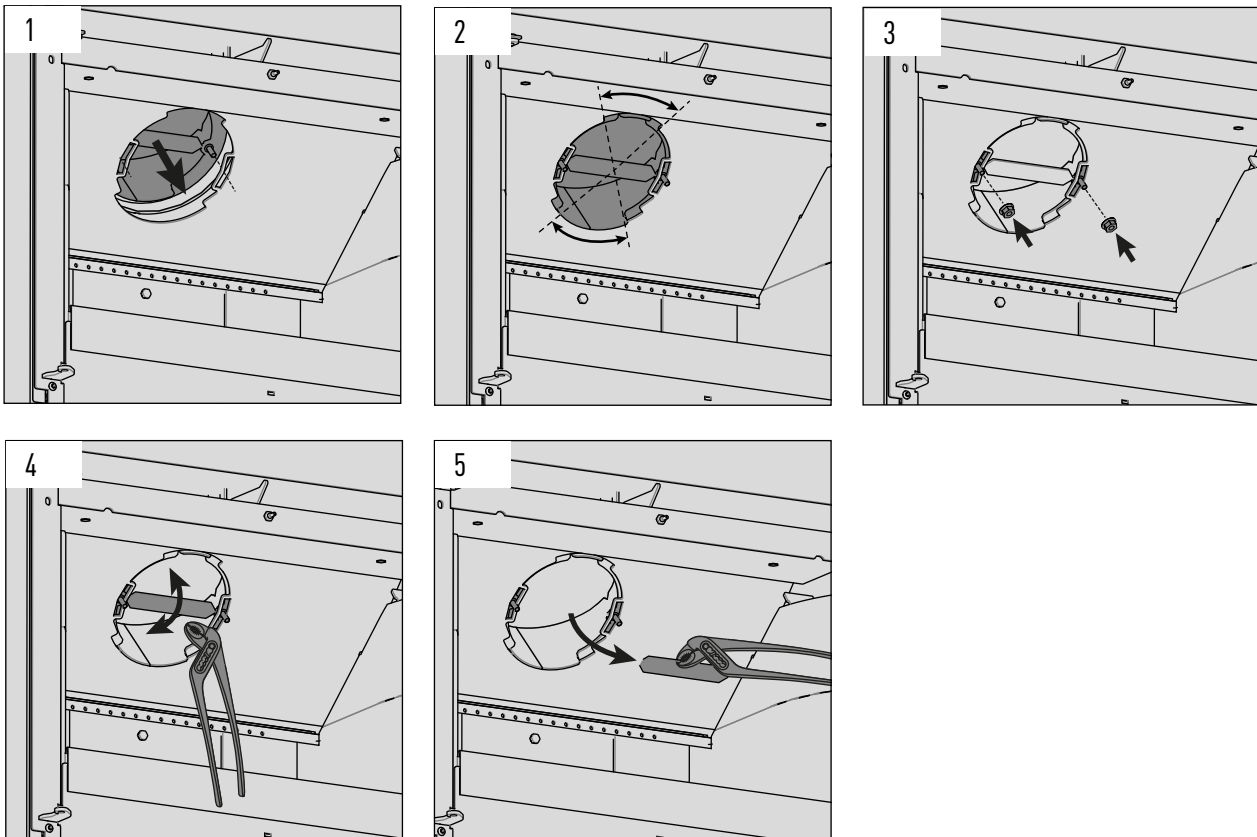

Hold the smoke outlet connector (which has already been connected to the duct) by the handle and attach it to the stove [figures 1 & 3]

Once the smoke outlet is in position, use pliers to break the handle off [figures 4 & 5].

N.B.: The smoke outlet can be turned to make it easier to connect to the duct [figure 2].

# FITTING THE DECORATIVE FRAME

## OPTION #1: FITTING THE THIN FRAME

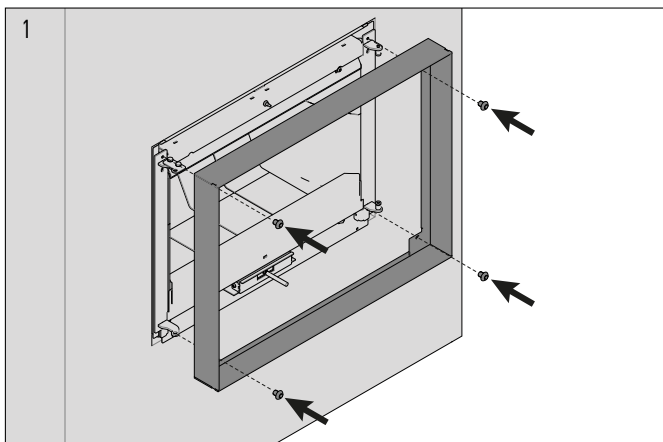

## OPTION #2: FITTING THE ADJUSTABLE 3 OR 4 SIDED FRAME

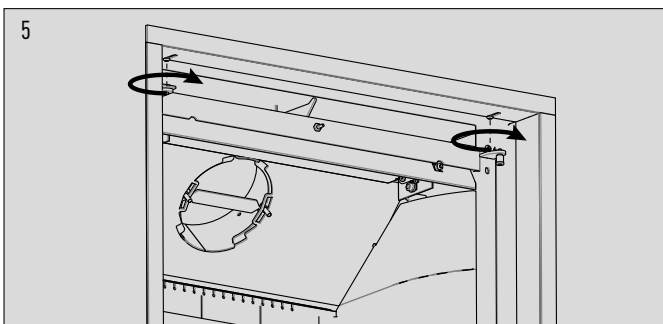
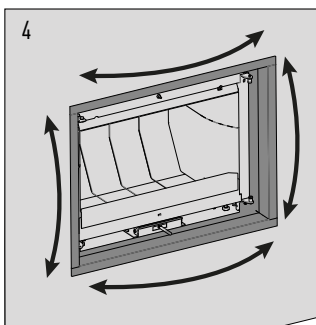
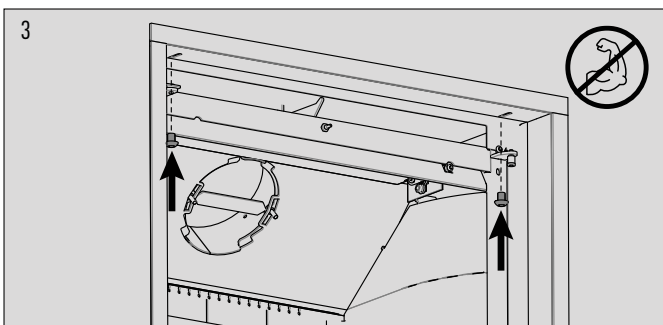
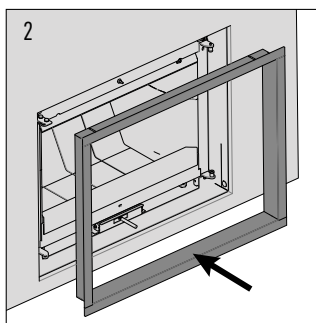
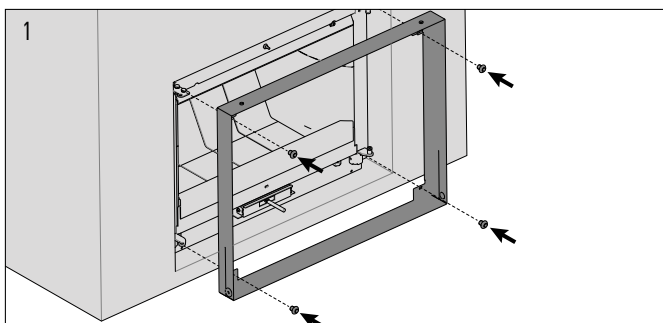

# FITTING INTERNAL PARTS AND DEFLECTOR BACK ON

Put the combustion chamber parts back on in reverse from p14 and p13  
Then put deflector back on as per below:

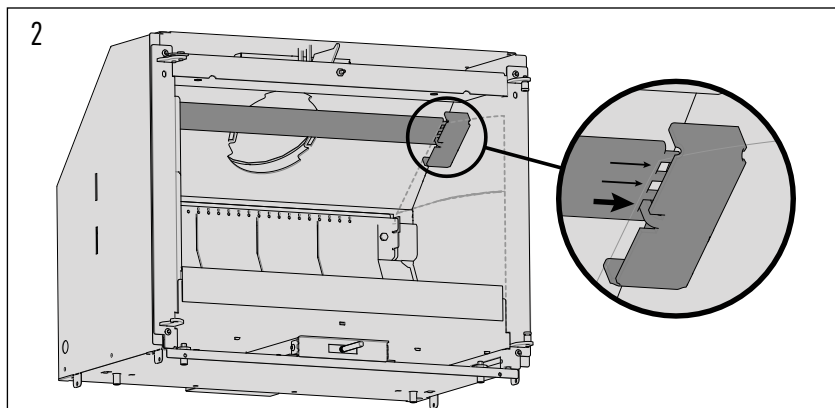
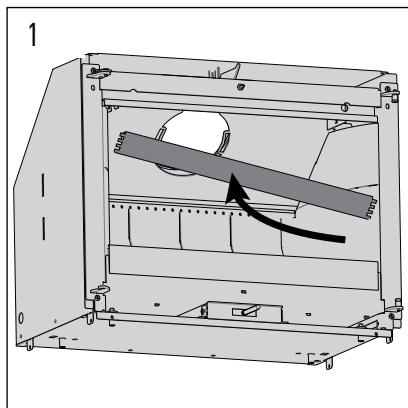

The default position of the vermiculite deflector housing is the highest position. If you have a "lazy" chimney, you can lower the housing to the second or third notches (figure 2).

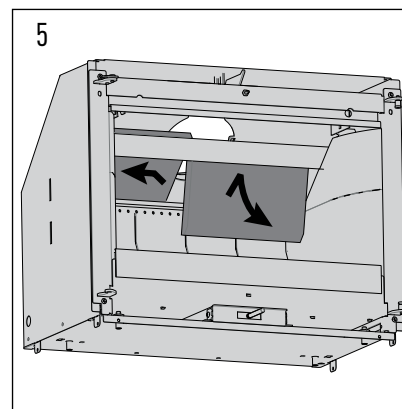
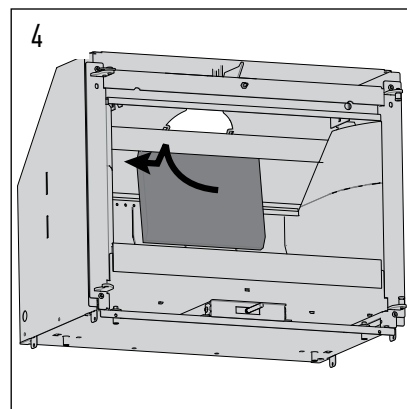
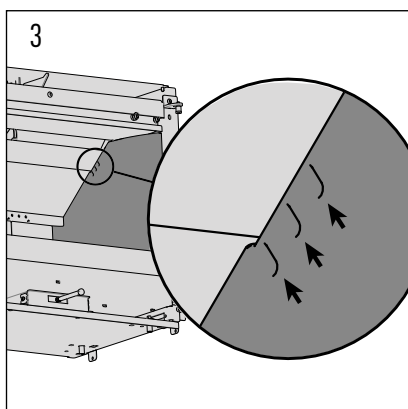

Use the markings on the side to get the right position for the deflector housing (figure 3).

# FLUE INSTALLATION

## PITCHED ROOF INSTALLATION

The top of the flue must be 400mm higher than the highest point of the roof. Alternatively, there must be a minimum distance of 3 meters from any higher section of roof.

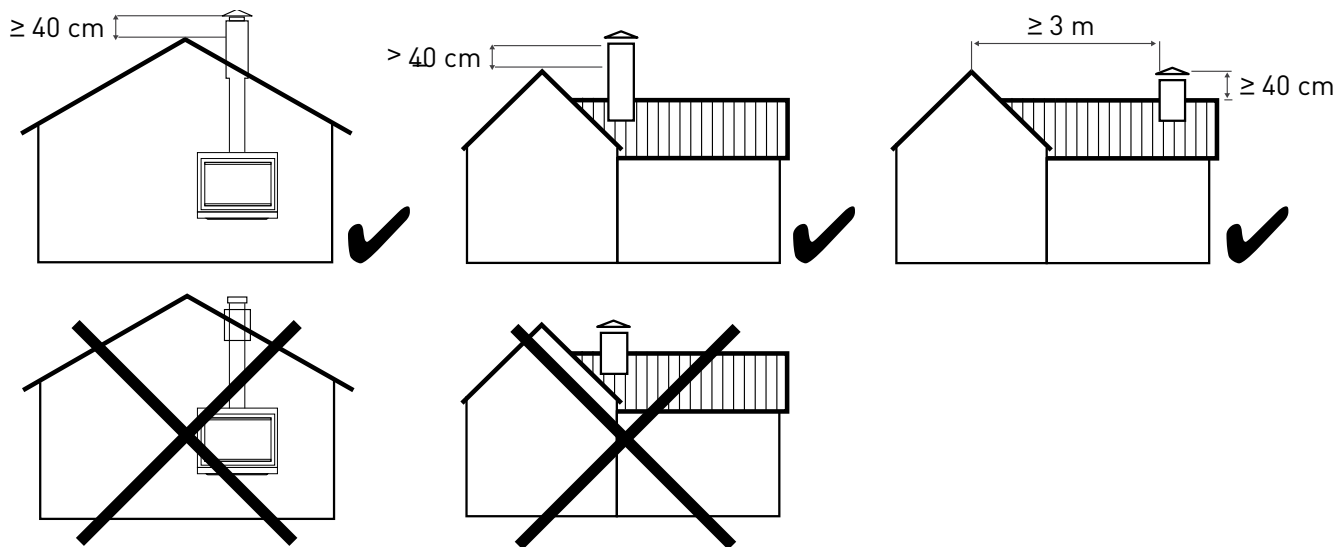

# OPERATION

The first time you light the fire, some fumes and smells may be released: make sure the room is well ventilated.

## What you should burn

- Untreated, air dried hardwood
- Split logs with a humidity content of less than 20%

## Do not burn

- Trash
- Painted plastic
- Coated or preservative treated wood
- Waste or black coal
- Inflammable liquids
- Fire gels
- Moist wood with a residual humidity content of more than 20% (this may cause sooting of the chimney).



### NOTE:

**Australian hardwood is extremely dense and we highly recommend using double split logs or "pizza oven" logs for optimum operation. Smaller logs will burn more cleanly and generate more heat making for a more efficient and enjoyable combustion.**

### WARNING:

- The Maximum load capacity of the STUV 6 is 4 kg of Hardwood/hour.
- Overloading the unit may result in damaging the heater and voiding the warranty.
- Misuse may lead to unhealthy and environmentally harmful emissions.
- Misuse may impact integrity of the heater and will void any warranty or guarantee.
- Burning only seasoned hardwood helps to protect the environment and lower emissions.

# TEST REPORT

## TEST REPORT NO ASFT22044-1 (PRELIMINARY REPORT)

<b>TESTING LABORATORY:</b>	Australian Solid Fuel Testing
<b>MANUFACTURER:</b>	Stuv
<b>MODEL:</b>	STUV 6
<b>WORK REQUESTED:</b>	Assessment of appliance to AS/NZS 4012:2014 for determination of Power Output and Efficiency and AS/NZS 4013:2014 for flue gas emission using hardwood fuel.
<b>ISSUE DATE:</b>	26/09/2022
<b>INVESTIGATING OFFICER:</b>	Steve Marland
<b>RESULTS:</b>	The Stuv 6 Insert solid fuel burning appliance produced an appliance particulate emissions factor of 1.1g/kg and an average efficiency of 68% for all burn rates, using hardwood that complies to AS/NZS 4014.1, when tested according to joint AS/NZS 4012, AS/NZS 4013 (2014).
<b>CONCLUSION:</b>	The Stuv 6 Insert solid fuel burning appliance complies with the requirement of a combined efficiency of not less than 60% and a particulate emissions factor of not greater than 1.5g/kg of hardwood that complies to AS/NZS4014.